

ELASTOMER SERIES
ELASTOMER KEYPAD
DESIGN GUIDELINES



***Elastomer Keypad
Design Guidelines
and Recommendations***

Elastomer Keypads

RECOMMENDED KEYPAD LAYOUT DIMENSIONS

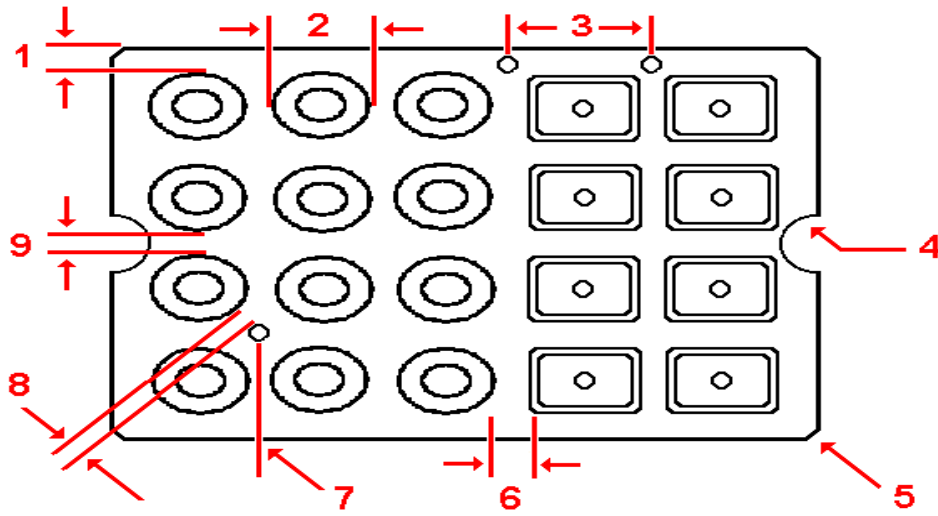

- | | |
|--|--|
| <ol style="list-style-type: none"> 1. Minimum distance from edge of keypad: 1.0 mm. 2. Typical membrane dimension: key size +2.5 mm. 3. Typical guide hole spacing: 30-50 mm. 4. Minimum radius dimension: 2.0 mm. 5. Typical corner radius dimension: =>1.0 mm. | <ol style="list-style-type: none"> 6. Minimum key pitch dimension: =>4.0 mm. 7. Minimum guide hole dimension: =>1.5 mm. 8. Minimum distance from hole to switch web: 1.0 mm 9. Minimum membrane spacing dimension: 1.0 mm. |
|--|--|

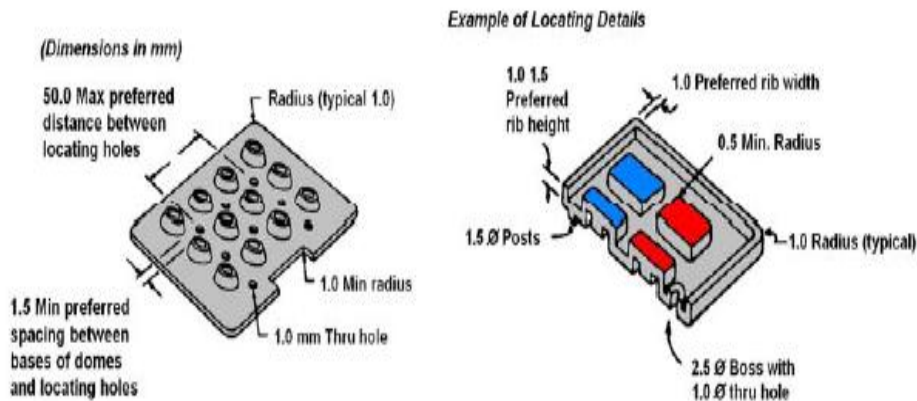

RECOMMENDED KEYPAD AND BEZEL DIMENSIONS

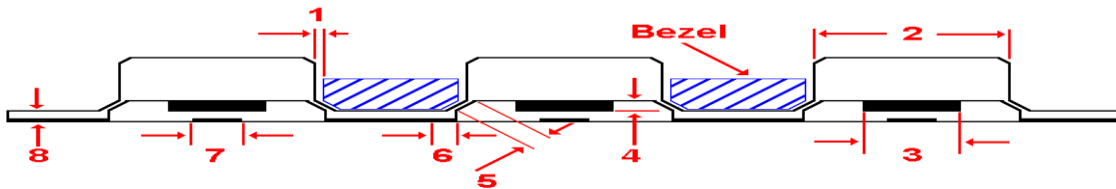

- | | |
|---|--|
| <ol style="list-style-type: none"> 1. Minimum clearance between bezel and keys: 0.3 mm. 2. Minimum key pitch dimension: 4.0 mm. 3. Typical pill size dimension (circular pills): 2.0 - 8.0 mm. 4. Typical pill thickness dimension: 0.4 - 0.5 mm. | <ol style="list-style-type: none"> 5. Typical chamfer angle dimension: 45°. 6. Typical chamfer dimension: 0.5 mm. 7. Typical air channel dimension: 1.5 ~ 2.0 mm. 8. Typical base thickness dimension: 1.0 mm. |
|---|--|

Elastomer Keypads
SILK SCREEN PRINTING GUIDELINES
MINIMUM GRAPHICS LINE AND LEGEND SPACING

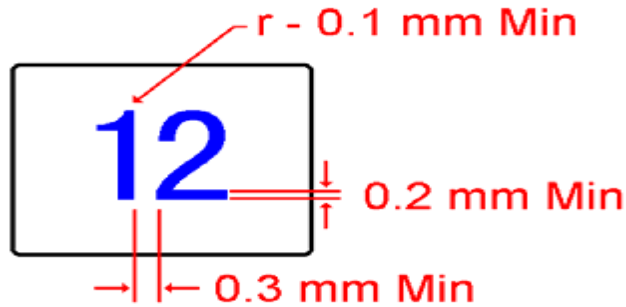

RECOMMENDED PRINTABLE AREA
KEYTOPS WITH FLAT TOP SURFACES

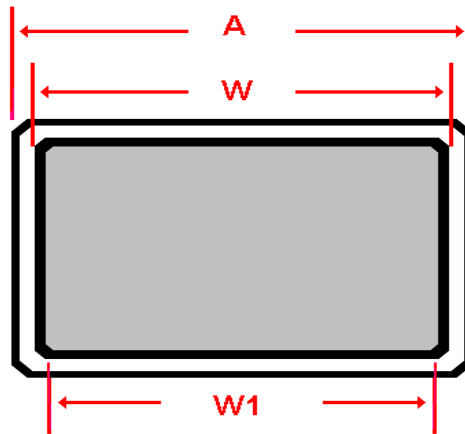

W = Printable area (colors)
W1 = Graphics area
Maximum graphics area $W1 \leq W - 0.4[\text{mm}]$

RECOMMENDED PRINTABLE AREA
KEYTOPS WITH SPHERICAL SURFACES

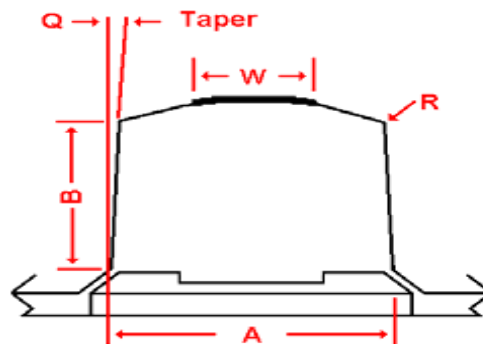

W = Printable area (colors)
Maximum graphics area $W \leq (2 \times B \times \tan(Q) \times R + 0.53) [\text{mm}]$

TACTILE FEEL

Creating the correct tactile “feel” is the art of elastomer keypad design and manufacturing. Defining tactile feel is a very complex task as so much of the final design decision is based upon subjective information.

Four major features found in elastomer keypads are interactive in determining the tactile feel of the finished product: **actuation force**, **key travel**, **contact force** and **return force**. The key element arising from this combination is the **Snap Ratio**, which is defined as:

$$\frac{F1-F2}{F1}$$

Where F1 = **Actuation (or Peak) Force** and F2 = **Contact Force**.

To design a keypad with a strong tactile feel the snap ratio must be a minimum of 0.4, and ideally 0.5 or greater. A snap ratio less than 0.4 will exhibit a weak tactile feel, but will have a longer life. This relationship may be expressed as a *Force Deflection Curve*.

Another important design consideration is the **Return Force** (F3), typically 25-30% of the Actuation Force but at least 30 gm to avoid sticking keys.

TYPICAL KEY PROFILES AND FORCE DEFLECTION CURVES

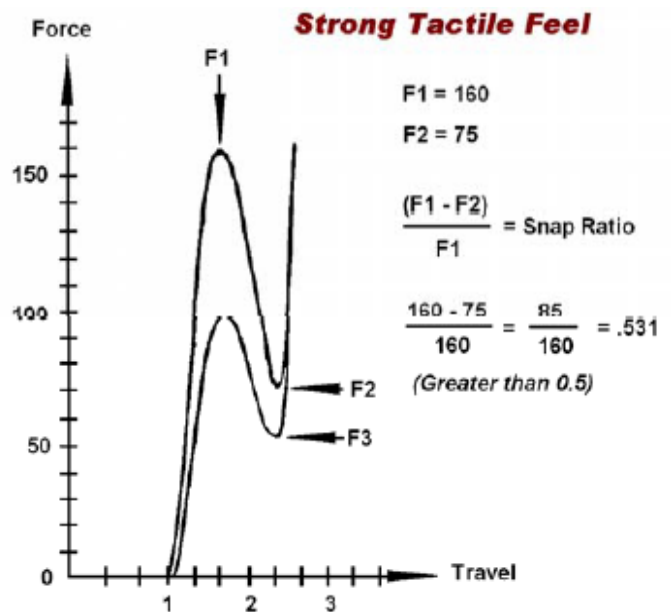
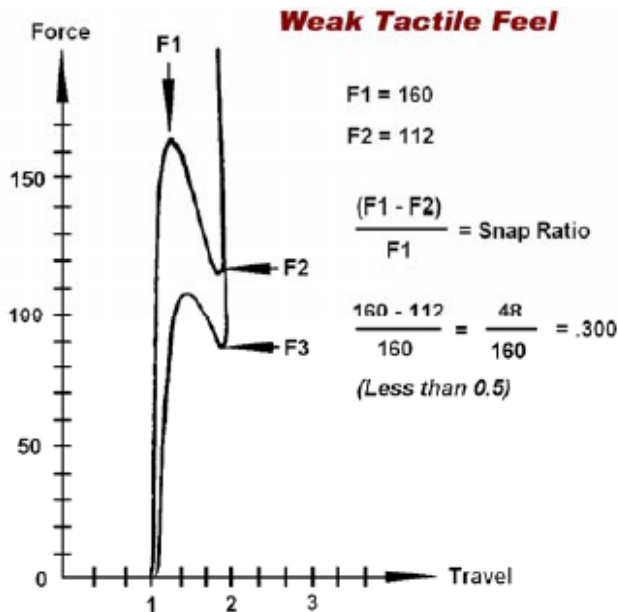
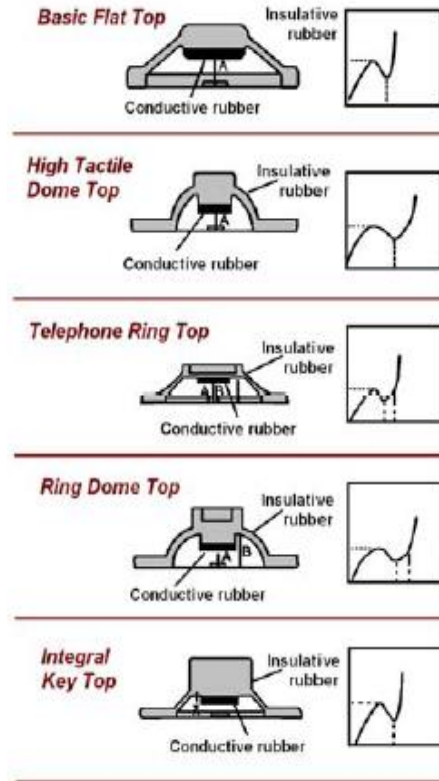

7323 Engineer Road, San Diego, CA 92111
Phone: (858) 279-430 Fax: (858)279-7963

sales@sigma6electronics.com ▪ www.sigma6electronics.com